

## HAND GESTURE CONTROLLED ACCELEROMETER BASED AUTOMATIC WHEELCHAIR

PRACHI SHARMA, ALPNA SINGH, RAHUL KUMAR SINGH, SNEHA YADAV & PARIDHI GUPTA

Department of Electronics and Communication Engineering, Moradabad Institute Of Technology, Moradabad (U.P.)

### ABSTRACT

*This paper is to develop a wheel chair control which is useful to the physically disabled person with his hand movement or his hand gesture recognition using Acceleration technology. Tremendous leaps have been made in the field of wheelchair technology. However, even these significant advances haven't been able to help quadriplegics navigate wheelchair unassisted. It is wheelchair which can be controlled by simple hand gestures. It employs a sensor which controls the wheelchair hand gestures made by the user and interprets the motion intended by user and moves accordingly. In Acceleration we have Acceleration sensor. When we change the direction, the sensor registers values are changed and that values are given to microcontroller. Depending on the direction of the Acceleration, microcontroller controls the wheel chair directions like LEFT, RIGHT, FRONT, and BACK. The aim of this paper is to implement wheel chair direction control with hand gesture reorganization.*

**KEYWORDS:** Accelerometer, Microcontroller, LCD, Wheel chair, Alcohol sensor, Depth sensor.

### INTRODUCTION

The demand of the physically handicapped and the aged are ever rising. The present wheelchairs do not have integration of technologies for their working. It either requires constant monitoring by the helper or hence lot of effort. Handicapped people face many problems in their life for surviving. To overcome this problem we are going to make a wheelchair which is hand gesture controlled or controlled by the hand movement (when hand tilted forward wheelchair move in forward direction, when hand tilted backward wheelchair move in backward direction, when hand tilted in right side it will move in right direction and when hand tilted in left side it will move in left direction).

Modified Features of wheelchair are as follows:

**Virtual Eye for Blinds:** In this proposed work, a simple, cheap, friendly user, virtual eye will be designed and implemented to improve the mobility of both blind and visually impaired people in a specific area. The proposed work includes an autoguided mode in which the wheel chair moves automatically without interruption of human

being.

- **Alcohol Detection System:** This system is basically a Embedded System which is combination of both software and hardware which can perform some specific functions using Microcontroller AT89S52. The Alcohol sensor on detecting the alcohol concentration will give the analog resistive output to the microcontroller then further alcohol detection message will be displayed on LCD. Microcontroller controls the L293D motor driver circuit which is responsible for working of the DC motor. Thus car will be stopped on detecting alcohol concentration and related information will go to nearby location through GSM.
- **Obstacle Avoidance System:** This can detect obstacles from its three sides- front, left and right side. The robot changes its direction of movement, whenever it detects any obstacle in its path from any side. Here, we will use three analog IR sensors to detect obstacles from the three sides of the robot. The three sensors will be placed in the front side, left side and right side of the robot pointing towards their respective side.

## LITERATURE SURVEY

Since years Research work has been going on Gesture Technology in many ways for the devices to be more flexible and portable. As discussed there are two types of Gesture Recognition methods: Vision-based and MEMS based. Much research has been done on Vision-based in the starting of this technology. Many applications for Home appliances, controlling machines has been developed using this method. In vision based method, Recognition can be done by taking Signs made by Eyes, head and hands. But because of many limitations with this method Research has been turned to MEMS method in the early years. In the MEMS based method, mainly two motion sensors accelerometer and Gyroscope can be used for Gesture Recognition. But no methods exist using Gyroscope because of computational burden. Accelerometer is the best suitable motion sensor for Gesture recognition applications. Using accelerometer, some researches are going to develop a portable system for the Disabled persons and also for the Handicapped people to move the wheel chair with simple gestures.

There are proposed methodologies in recent times which involve various gestures like hand gesture, accelerometer & voice controlled, EEG based system etc.

### A. Hand Gesture

In this paper, they utilized the acceleration data to recognize the hand gestures and then transfer the gesture information which indicates certain motion commands into the wheelchair's smooth motions. It's a trial method to realize the natural interaction for the older and handicapped with the wheelchair through the hand gestures.

### B. Accelerometer and Voice Controlled

This work describes a wheelchair for physically disabled people & developed it using voice recognition kit and MEMS motion sensor. A user dependent voice recognition system had been integrated in the wheelchair. In this way they had obtained a wheelchair which can be driven using both motion and voice commands.

### C. EEG System

This system proposes two control modes: Use of the gyroscope Emotive EPOC headset in order to detect head movements. Emotive EPOC headset is a device that measures EEG activity from 14 saline electrodes. These electrodes are arranged according to the 10/20 sys-tem.

The Nav Chair Assistive Wheelchair Navigation System, The Nav Chair has application for the development and testing of shared control systems where a human and the machine share control of a system and the machine can automatically adapt to human behaviours. The Nav Chair shares vehicle control decisions with the wheelchair operator regarding obstacle avoidance, safe object approach, maintenance of a straight path, and other navigational

issues, to reduce the motor and cognitive requirements for operating a power wheelchair.

Touch Screen Based Direction and Speed Control of Wheel Chair for Physically Challenged, this paper describes an intelligent motorized wheel chair for handicapped person using touch screen technology. It enables a disabled person to move around independently using a touch screen application which is interfaced with motors through micro-controller. When we want to change the direction, the touch screen sensor is modelled to direct the user to the required destination using direction keys on the screen and that values are given to micro-controller. Depending on the direction selected on the touch screen, micro-controller controls the wheel chair directions. The speed controller works by varying the average voltage sent to the motor. This is done by switching the motors supply on and off very quickly using PWM technique.

All the above discussed systems are though sophisticated but they are either too complex in operation or complex in their circuitry and are not cost effective. Here our developed Wheel chair system is simple in operation, has good response & reasonably affordable for most of the users.

## PROPOSED WORK

Instead of using all these existing and above discussed technology we can use a MEMS sensor that would detect the tilt according to the hand movement of user and provides RF signal to the microcontroller that controls the direction movements of motors along with- An ultrasonic sensor used for obstacle detection, a virtual eye for blind for their assistance, an alcohol detection device to prevent accident while using wheelchair on roads and all these will help in the easily survival of the handicapped and blind persons.

## METHODOLOGIES

As we discussed earlier this consists of different- different modules which together forms an automatic and modern wheelchair for the handicapped people. The project is been divided into sub modules which are been explained below:

### Module A: Accelerometer based hand Gesture controlled wheelchair

Implementation of this proposed problem mainly involves two steps. They are gesture recognition and controlling direction of wheelchair using microcontroller based on the received gesture commands. The block diagram of the system is shown in Figure 1 Transmitter Block Diagram, 2 Receiver Block Diagram. As overviewed in the block diagram the hand gesture is sensed by accelerometer using the instrumented glove approach. The ADXL 330 accelerometer which convert the hand position into 3-Dimensional Output. The values obtained from the accelerometer are analog values which should be further converted into digital values so they can be used by the microcontroller. The accelerometer analog outputs are converted into digital with the help of ADC 0809. ADC converts the data from sensor and proceeds to the microcontroller (P89V51RD2) for further conversion and calibration. Microcontroller gets the data from the accelerometer and converted into ASCII code for LCD display. LCD display the X— Y—Z values and display the values on the LCD.

We use the readings obtained from accelerometer for wheel Chair movements. As the position of the hand changes, data from the accelerometer and microcontroller also changes automatically. We use HT12E encoder for serial communication. Data from the microcontroller is connected to the input pins of encoder and transmits via output pins of the encoder.

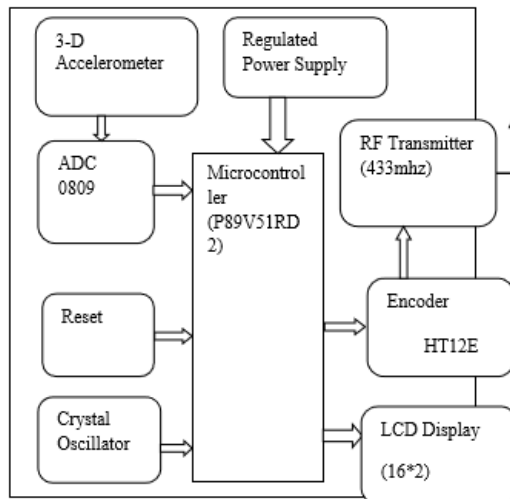

**Fig.1:** Block Diagram of Transmitter

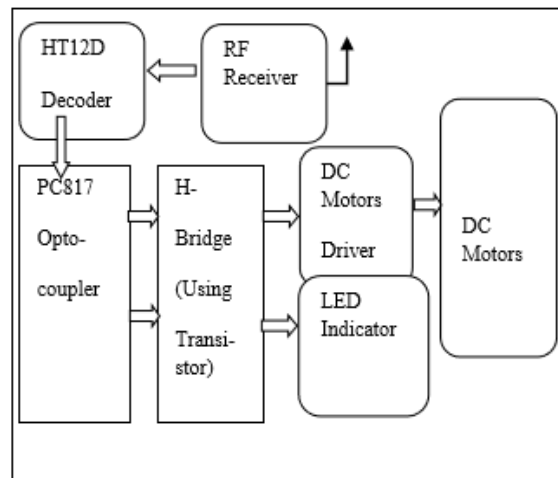

**Fig. 2:** Block Diagram of Receiver

Output from the encoder is connected to the RF transmitter module and transmit with frequency 433 Mhz. The RF receiver module sends it to the decoder which further decodes the signal and gives the signal to the opto-coupler and H-Bridge circuitry which drives the motors of wheel chair based on the hand gesture and same result shown by the LCD.

### Module B: Virtual Eye for the Blinds

In order to overcome the difficulties in the existing method and to provide the cost effective and user friendly system for blind navigation, the following design is proposed. The wheel chair has two mode in one mode the wheelchair is controlled by the person using its hand gesture and in second mode is the autoguided mode which works as a virtual eye for blinds.

In this the wheel chair moves automatically by pressing a button by which it will start working in autoguided mode. The wheelchair moves automatically if any obstacle comes in path it will sense that and automatically changes its path.

In this a depth sensor is also their which will help to avoid accident due to any stairs or other depth. If stairs or any other type of depth will come in path it will sense that and will stop the wheel chair and move back and then into other direction.

### Module C: Alcohol detection device

Hardware mainly consists of MQ3, microcontroller AT89S52, L293D motor driver, 16\*2 LCD display, DC motor. The software is basically an embedded C programming.

**a) Alcohol sensor MQ-3:**

It is suitable for detecting alcohol concentration just like common breath analyzer. It has a high sensitivity and fast response time.

**b) AT89S52 microcontroller:**

The AT89S52 is the microcontroller used here which is a low-power, high-performance CMOS 8-bit microcontroller with 8K bytes of in-system programmable Flash memory. The on-chip Flash allows the program memory to be reprogrammed in-system or by a conventional non-volatile memory programmer. By combining a versatile 8-bit CPU with in-system programmable Flash on a monolithic chip, the Atmel AT89S52 is a powerful microcontroller which provides a highlyflexible and cost-effective solution to many embedded control applications. The AT89S52 provides the following standard features: 8K bytes of Flash, 256 bytes of RAM, 32 I/O lines.

**c) L293D motor driver:**

This will generate a signal to the converter of the circuit and thus controls the operation of the motor. We cannot connect motor directly with the microcontroller, so that the operation of DC motor takes place smoothly.

**d) GSM SIM 300 module:**

This modem can accept any GSM operator SIM card and act just look like a mobile phone with its own unique phone number. Advantage of this modem will be that you can use its RS232 port to communicate and develop embedded application. This modem can either be connected to pc serial port directly or to any microcontroller. It can be used to send and receive SMS or make /receive voice calls.

**Module D: Obstacle Avoider Circuit**

This robot can detect obstacles from its three sides- front, left and right side. The robot changes its direction of movement, whenever it detects any obstacle in its path from any side. Here, we will use three analog IR sensors to detect obstacles from the three sides of the robot. The three sensors will be placed in the front side, left side and right side of the robot pointing towards their respective side. Whenever an obstacle comes in front of any sensor, there will be a change in the output of that particular analog IR sensor and this change will be detected by the AT89S52 microcontroller. But the outputs of the three analog IR sensors are analog in nature, so these signals cannot be processed directly by the microcontroller. For this, we will use the ADC of the AT89S52 microcontroller to convert the analog signals to digital values. After converting the analog signals of analog IR sensors to digital values, the AT89S52 microcontroller will compare the sensor values with a reference value i.e threshold value(3V in our case). According to the output of the above comparisons, the AT89S52 microcontroller will send the required control signal to the DC motor driver (L293D) of the robot to move the robot in forward, left or right direction. The above processes of ADC conversions, sensors output comparison and robot control continues forever till the power source is there.

**CONCLUSION**

From the above obtained results, we conclude that the developed head gesture based control of wheel chair is tested and works satisfactorily in an indoor environment with minimum assistance to the person suffering with Quadriplegia or Paraplegia. It has a good response with MEMS activating the motors connected to the wheels of the chair. The response and distance covered by wheelchair can be further improved if the gear system connected to motors are replaced by crank and pinion joint which has less friction and mechanical wear & tear. In future we

would work on this concept to improve the response and embed more sensors like proximity, ultrasonic, GPS to guide the impaired person in much more better way and use this wheel chair even under outdoor conditions.

## REFERENCES

- [1] S. Tameemsultana and N. Kali Saranya “Implementation of Head and Finger Movement Based Automatic Wheel Chair” Bonfring International Journal of Power Systems and Integrated Circuits, Vol. 1, Special Issue, December 2011.
- [2] Naveen Kumar, Rohini Deshpande, S. S. Manvi “Advanced Communication System for Quadri-plegics using PC and Accelerometer” International Journal of Emerging trends in Engineering and Development, ISSN 2249-6149 Issue1, Vol. 3(November-2011).
- [3] Luis Montesano, Javier Minguez, Marta Diaz and Sonu Bhaskar “Towards an Intelligent Wheel-chair System for Cerebral Palsy Users” IEEE transactions on neural systems and rehabilitation engineering, vol. 18, no. 2, April 2010.
- [4] Gowthaman.A, Ranjithkumar. R, Varunarajan. M V, Ganesh Babu.P U.G. Student “Wheel Chair Motion Control Based On Hand Gesture Recognition” International Journal of Innovative Research in Technology & Science (IJIRTS) ISSN: 2321-1156.
- [5] Rahul C. M., Nalini C. Iyer "accelerometer and voice controlled wheel chair” Proceedings of 4th SARC International Conference, 30th March-2014, Nagpur, India, and ISBN: 978-93-82702-70-2.
- [6] Ericka Janet Rechy-Ramirez, Huosheng Hu and Klaus McDonaldMaier “Head movements based control of an intelligent wheelchair in an indoor environment” Proceedings of the 2012 IEEE, International Conference on Robotics and Biomimetics, December 11-14,2012, Guang-zhou, China, 978-1-4673-2126-6/12.
- [7] Shreedeeep G., Somsubhra Mukherjee & Soumya Chatterjee “Intelligent Gesture Controlled Wireless Wheelchair for the Physically Handicapped” Proceedings of Fifth IRAJ International Conference, 2013, India, ISBN: 978-93-82702-29-0.
- [8] Pooja P. Gundewar and Hemant K. Abhyankar, “A Review on an Obstacle Detection in Navigation of Visually Impaired”, International Organization of Scientific Research Journal of Engineering (IOSRJEN), Vol.3, No.1 pp. 01-06, January 2013.
- [9] Bhuvanesh Arasu and Senthil Kumaran, “Blind Man”s Artificial EYE An Innovative Idea to Help the Blind”, Conference Proceeding of the International Journal of Engineering Development and Research(IJEDR), SRM University, Kattankulathur, pp.205-207, 2014.
- [10] Amjed S. Al-Fahoum, Heba B. Al-Hmoud, and Ausaila A. Al-Fraihat, “A Smart Infrared Microcontroller-Based Blind Guidance System”, Hindawi Transactions on Active and Passive Electronic Components, Vol.3, No.2, pp.1-7, June 2013.
- [11] S.Bharathi, A.Ramesh, S.Vivek and J. Vinoth Kumar, “Effective Navigation for Visually Impaired by Wearable Obstacle Avoidance System”, International Journal of Power Control Signal and Computation (IJPCSC), Vol.3, No.1, pp. 51-53, January-March 2012